

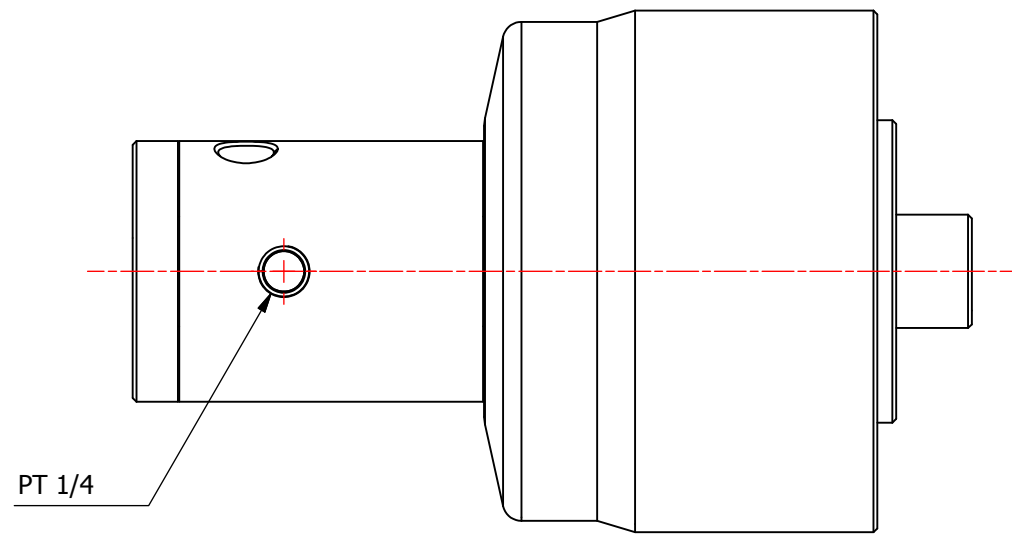

내경 : 100
 스트로크 : 20

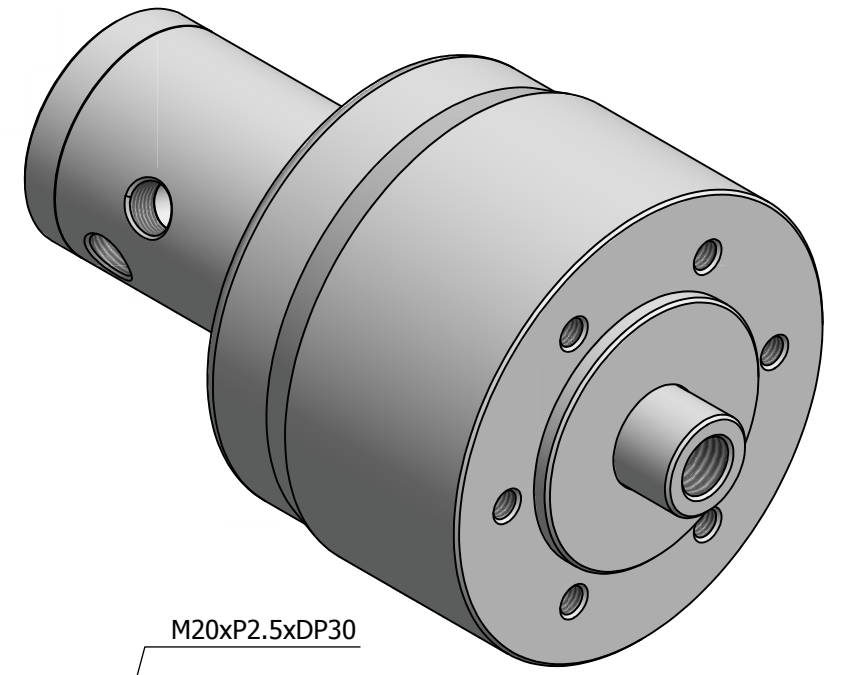
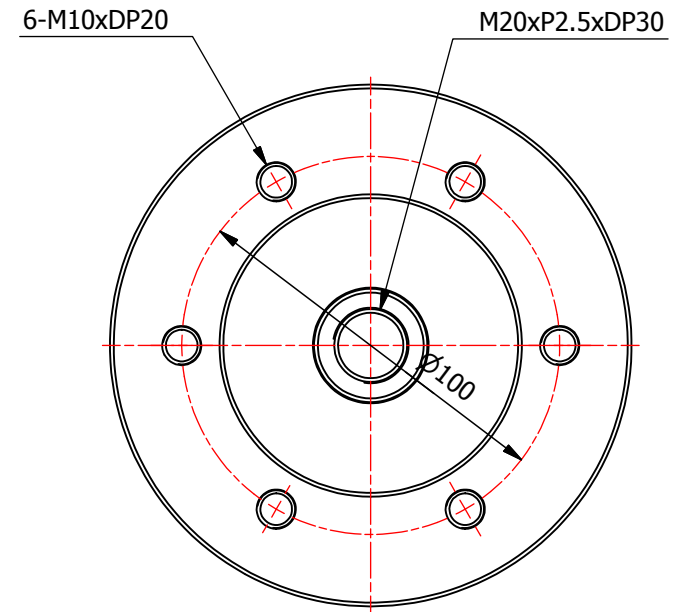

NO.	PART NAME	Q'TY	MAT'L	SIZE	REMARK
 DONG HYUP MANUFACTURING PRODUCTS					
DRAWN				DHC	
SCALE	DRAWN	DESIGN	APPROVE	NAME	DHC-1020
UNIT				RELATIONAL DWG.NO.	
TOLER'				DWG. NO.	
DATE					